

Model 1630

Mobile hoist 1630

A budget friendly solution for home care



- Compact and reliable
- An integrated spreaderbar for convenience and use with Handi-slings
- Emergency down feature
- Ergonomic handle bar provides smooth steering making it easy to maneuver
- Width adjustable base for easy positioning. Low profile chassis with easy-to-roll castors for clearance under low objects



Lift & Care systems for people with reduced mobility

www.handimove.com

Mobile hoist 1630

● Dimensions (inch / mm)

A	51.97 / 1320
B	26.97 / 685
B'	19.49 / 495
B1	42.91 / 1090
C	16.73 / 425
C1	10.04 / 255
C2	24.02 / 610
D	4.33 / 110
H	21.26 / 540
H'	48.82 / 1240
H1	44.49 / 1130
H2	70.08 / 1780
H3	79.53 / 2020
L	45.28 / 1150
L'	11.02 / 280
L1	46.26 / 1175
L2	52.17 / 1325
T	22.83 / 580
T'	5.71 / 145

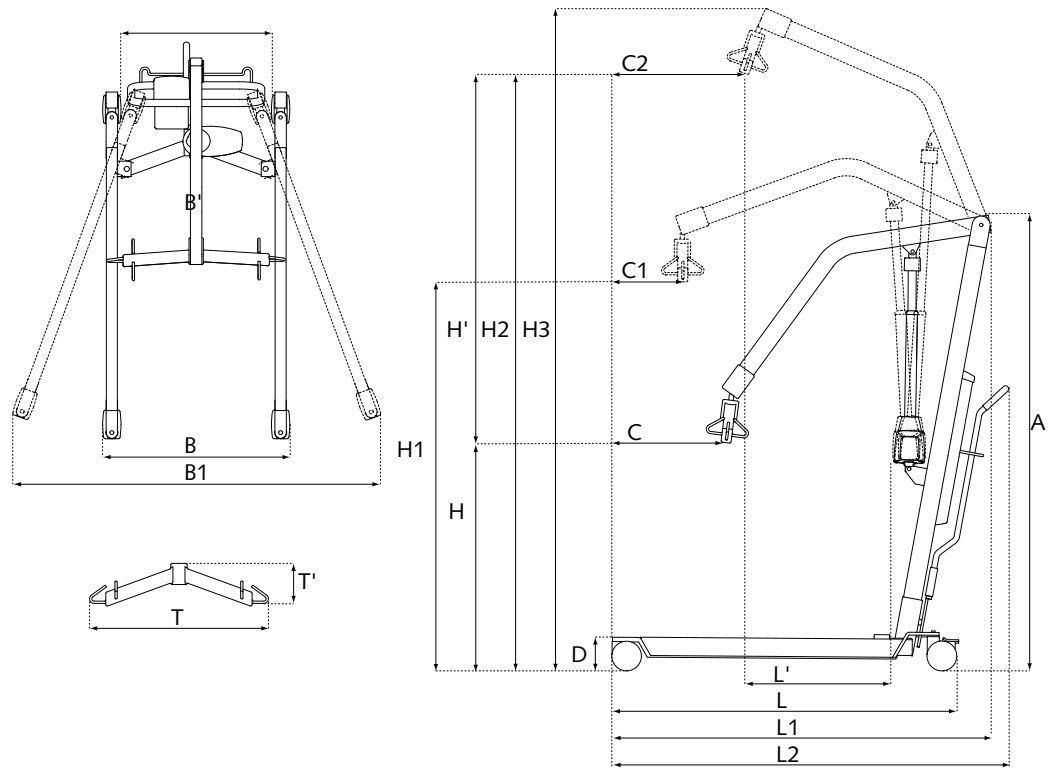

● Specifications

Max. lifting capacity	386 Lbs / 175 kg
Emergency down	mechanical
Weight	90 Lbs / 41 kg
Batteries	sealed and maintenance-free 2 x 12 Vdc; 6,5 - 7,2 Ah
Number of lifts with fully charged batteries	120 at 198.42 Lbs / 90 kg / 19.69 inch / 50.00 cm
Charger	input: 0.9 A 100 - 240 Vac 50 -60 Hz, class II output: 24 Vdc Max 1.3 A
Turning radius	51.18 inch / 1300 mm

● Speeds (inch/cm per sec.)

Raising (unloaded)	1.42 / 3.60
Lowering (unloaded)	1.42 / 3.60
Raising (load 198 Lbs / 90 kg)	1.14 / 2.90
Lowering (load 198 Lbs / 90 kg)	1.3 / 3.30
Raising (max. load)	0.91 / 2.30
Lowering (max. load)	1.18 / 3.00

For free demonstration or further information

